

ANHYDROUS AMMONIA FITTINGS AND ANCILLARY EQUIPMENT

Whether estimating costs for a proposed anhydrous ammonia installation or purchasing equipment for a specific application, it is necessary to have a thorough understanding of the types of equipment and fittings that are suitable for anhydrous ammonia service. Some ammonia service equipment is shipped by the manufacturer with all ammonia controls and fittings installed. With other equipment the user is expected to supply the additional items required to put the equipment into service. The information contained in the following paragraphs describes ammonia equipment and ammonia pipe fittings in general.

LaRoche industries can design, supply, install and service your ammonia equipment or can recommend a source for such services.

Ammonia corrodes copper, copper alloys such as brass and bronze, and zinc. Iron, steel and stainless steels are compatible with ammonia. Therefore, the usual types of pressure regulators, pressure gauges, brass valves, bronze-seated unions, and galvanized pipe and fittings will not be satisfactory. The following general specifications for ammonia fittings and ancillary equipment are given as a guide. On request, we can recommend specific manufacturers or suppliers and indicate the proper material specifications for equipment items.

Requirements for anhydrous ammonia equipment can be found in OSHA 29CFR Part 1910.111. Recommendations for anhydrous ammonia equipment can be found in ANSI (American National Standards Institute) Booklet K61.1 (1989).

CYLINDER VALVE CONNECTION

A cylinder yoke or locknut/nipple/bushing/union combination is used to connect a flexible hose to an ammonia cylinder.

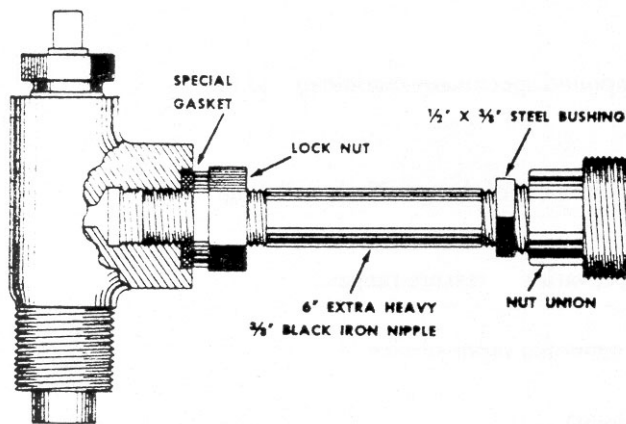

Figure 1: Cylinder Valve Connector - Locknut and Nipple Type

The height of a cylinder varies up to 1/2", requiring the use of a flexible connection to prevent strain on attached equipment. The use of an ammonia hose is the most satisfactory method of providing this flexibility.

A 3/8" nipple and locknut connection is shown in Figure 1. The composition gasket ensures a leak-proof joint. These gaskets are supplied by LaRoche Industries.

TB-3-2

Rev. 1/90 page 1 of 2

The technical data in this bulletin are based on information which we believe to be accurate. However, nothing in this bulletin is to be construed as an expressed or implied warranty. Regarding the accuracy of the data or the use of any of the products herein described. Nothing contained herein should be considered as a recommendation for the use of any product or method in violation of any valid patent now effective or which may issue hereafter. All risks of liability rest solely with the user of the data or products herein described.

LaRoche Industries Inc.
1100 Johnson Ferry Rd. N.E. / Atlanta, GA 30342
(404) 851-0355

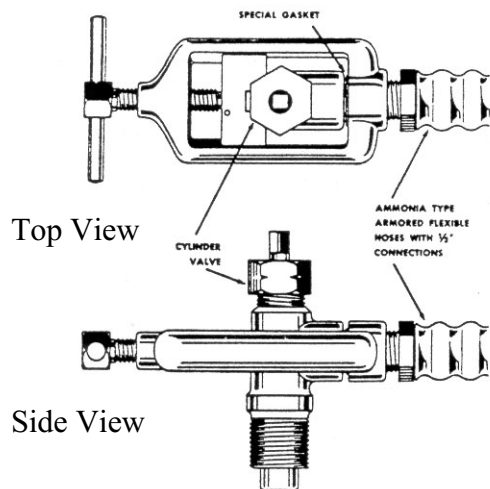

Figure 2 - Cylinder Valve Connector - Yoke Type

A cylinder yoke connection is shown in Figure 2. The connecting operation is simplified with the use of a yoke, since it may be tightened by hand. The alternative locknut and nipple type connection requires the use of wrenches for tightening. The same gasket is used to ensure a leakproof connection. the yoke is permanently attached to the 1/2" flexible hose.

FITTINGS

Elbows, tees, crosses - 2000# Forged Steel.
Couplings, caps - 3000# Forged Steel
Bushings, plugs - Forged Steel

FLEXIBLE HOSE

Stamped for anhydrous ammonia service, with steel ferruled couplings attached, stainless steel braid reinforced, 350 PSI working pressure, 1750 PSI minimum burst pressure.

HYDROSTATIC RELIEF VALVE

Stamped for anydrous ammonia service, spring loaded. designed to protect hose piping from excessive hydrostatic pressure.

METERING DEVICES

Vapor Ammonia service - Flow rate indicator.
Liquid Ammonia Service - Magnetic liquid level gauge - Flow rate indicator - Weighing Device - Sight glass - Turbine meter - Positive displacement meter.

PIPE

Schedule 80 (Extra Heavy) black iron.

PIPE JOINT COMPOUND

XPando, teflon (tape or paste) or any compound specifically recommended for ammonia service.

PIPE JOINTS

Threaded or welded depending on the requirement of the specific installation.

PRESSURE GAUGES

Stainless steel Bourdon tube, ammonia type, various pressure ranges.

PRESSURE REGULATOR

Aluminum, iron, or steel construction for ammonia vapor service.

UNIONS

3000# AAR Type (Ground steel-to-steel joint).

VALVES

Steel, specified by manufacturer as suitable for anhydrous ammonia service (check valves, excess flow valves, angle valves, globe valves, bar stock valves, bleed valves solenoid valves).

VAPOR RELIEF VALVES

Stamped for ammonia service, spring loaded. designed to protect storage containers from excessive vapor pressure.